

ELECTRONIC KIT'S MANUAL

INSTALLATION



**The electronic kit be installed
by a professional
PWC dealer or Flyboard distributor**



FB02A10

VOIR DETAIL

FB02A11



FB02A14



FB02A15









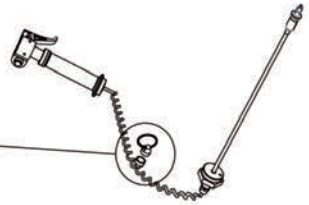
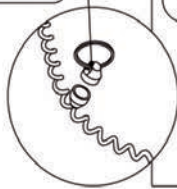



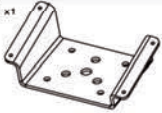
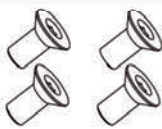

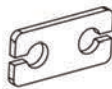





OR

FB02A16

FB02A17

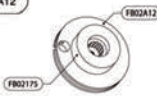

FB02A16	01	PRORIDER TRIGGER	
FB02A17	01	MAGNETIC CONNECTION	
FB20A15	01	ELECTRONIC STABILIZER ARM	
FB20A14	01	ELECTRONIC CONNECTION CABLE	
FB20A11	01	BRAIN ENGINE	
FB20A10	01	ELECTRONIC ACCESSORY KIT	
ITEM	NB.	DESIGNATION	

FB02A13	01	EQUIPPED PULLEY SCREW	
FB02175	01	FOAM	
FB02A12	01	EQUIPPED PULLEY	
FB02114	01	RING Ø3	
FB02117	01	CONNECTION ELECTRONIC HOUSING POD	
FB02116	01	SHRINK TUBING	
FB02115	01	ENDPIECE CABLE CLAMPING SCREW	
FB02113	01	BIG CLAMP	
FB02112	01	ENDPIECE CABLE	
FB02111	04	CABLE GLAND GRUBSCREWS	
FB02110	01	CABLE GLAND	
FB02109	01	ADAPTER BEAM CAP	
FB02108	01	UNIVERSAL WIRING HARNESS ADAPTER	
FB02107	04	CLAMPS	
FB02106	01	THROTTLE HOOK RETURN	
FB02105	01	THROTTLE ELASTIC RETURN	
FB02104	01	COUPLING CABLE PLATE	
FB02103	01	THROTTLE CABLE	
FB02102	04	HOUSING FIXING SCREW	
FB02101	01	CASE SUPPORT	
ITEM	NB.	DESIGNATION	

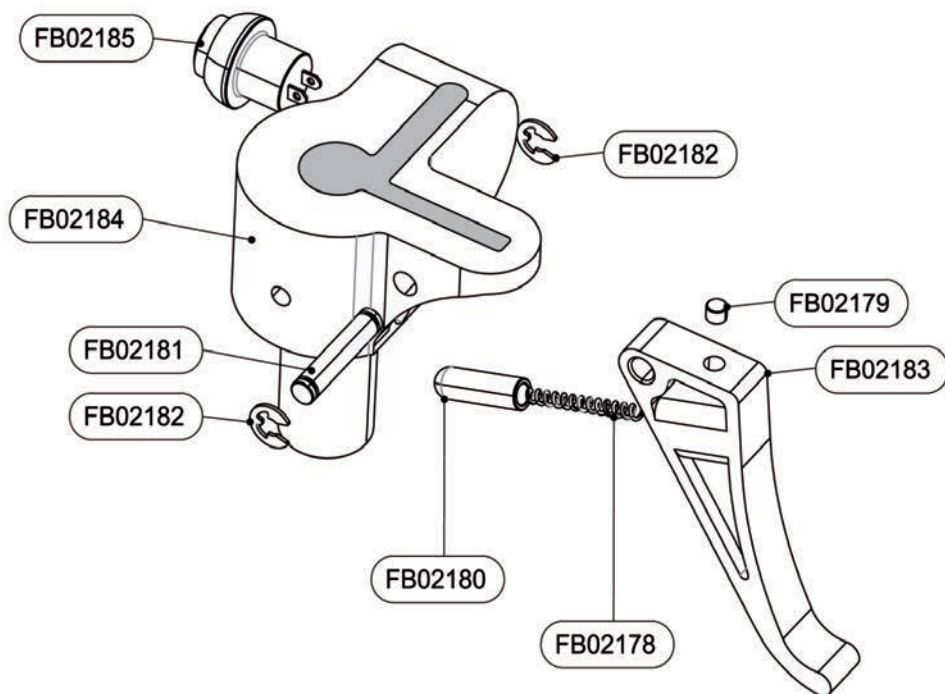

FB02185	01	ON/OFF SWITCH	
FB02184	01	TRIGGER	
FB02183	01	TRIGGER BODY	
FB02182	01	CIRCLIPS	
FB02181	01	TRIGGER PIN	
FB02180	01	STOP	
FB02179	01	TRIGGER MAGNET CONNECTION	
FB02178	01	SPRING L32	

ITEM.	NB	DESIGNATION
-------	----	-------------

FB02101



INSTRUCTIONS:

SET THE BRACKET ITEM.FB02101 UNDER THE BATTERY'S STRAPS

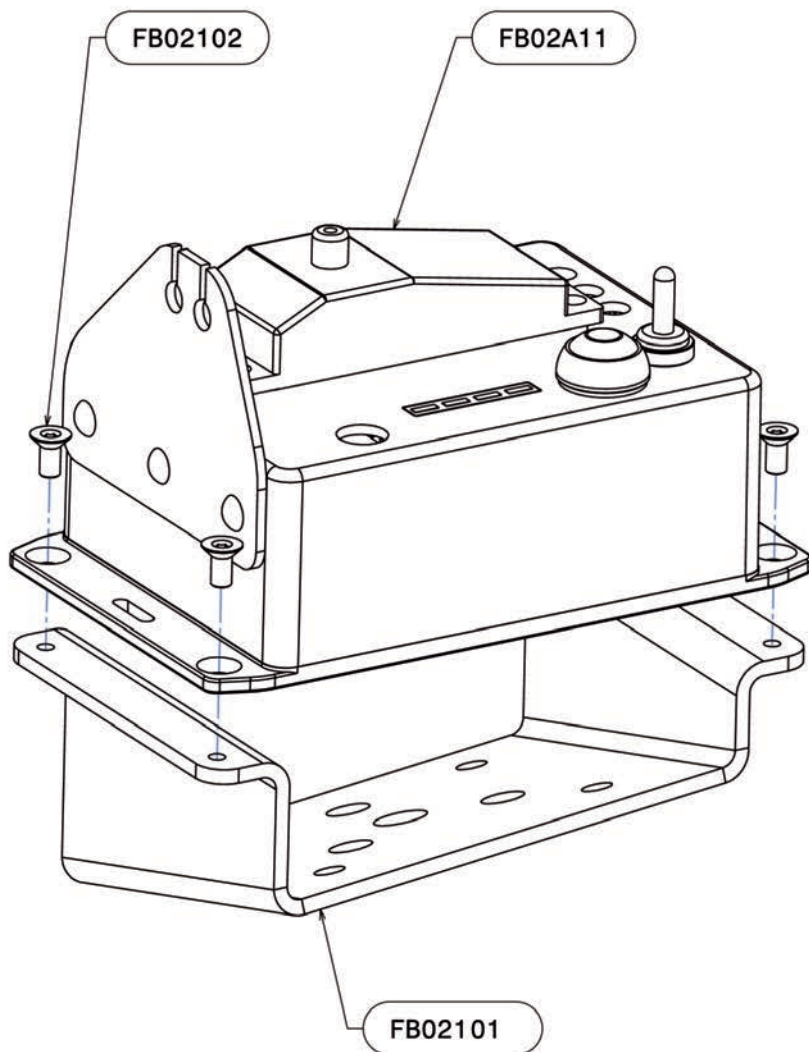
**INSTRUCTIONS:**

SET THE CASE FB02A11 ON THE SUPPORT FB02101 WITH THE SCREW FB02102

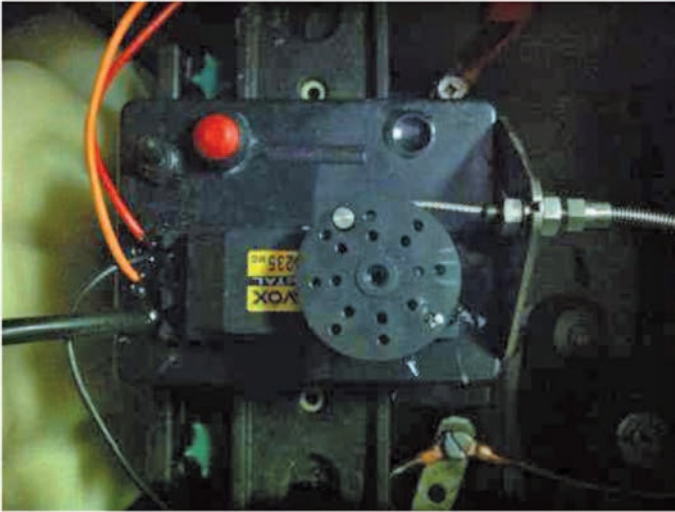
**INSTRUCTIONS:**

1. CONNECT THE RING EYELET RED WIRE TO + BATTERY
2. CONNECT THE RING EYELET BLACK WIRE TO - BATTERY

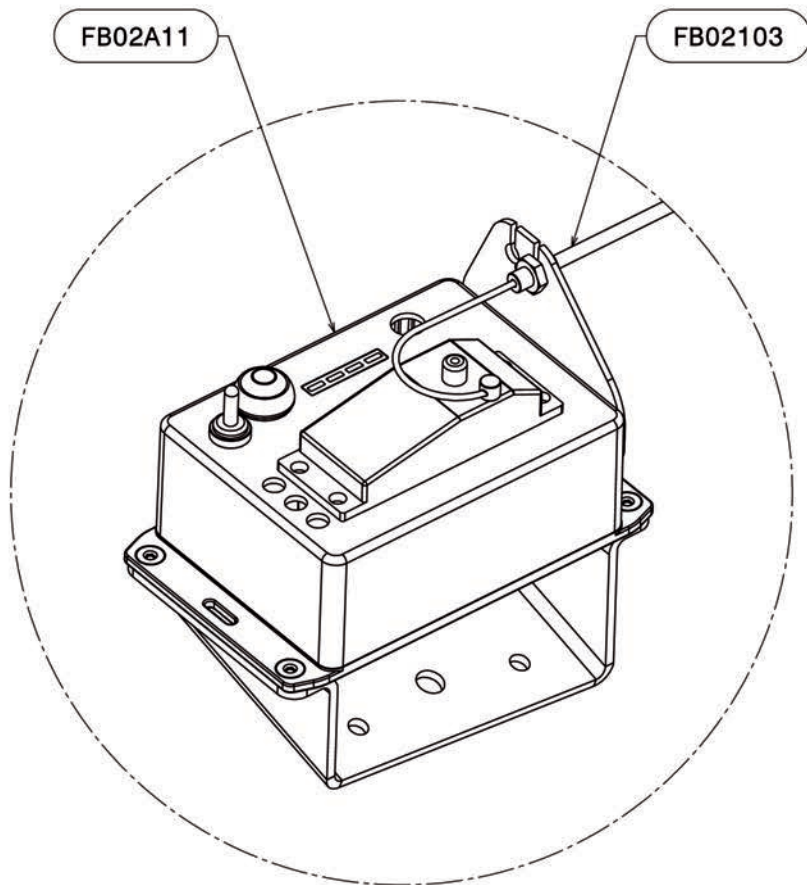
**INSTRUCTIONS:**

SET THE CABLE FB02103 ON THE PLATE OF THE CASE FB02A11

SET THE THROTTLE CABLE REFERRING TO THE APPROPRIATE ASSEMBLY SHEET

FB02103

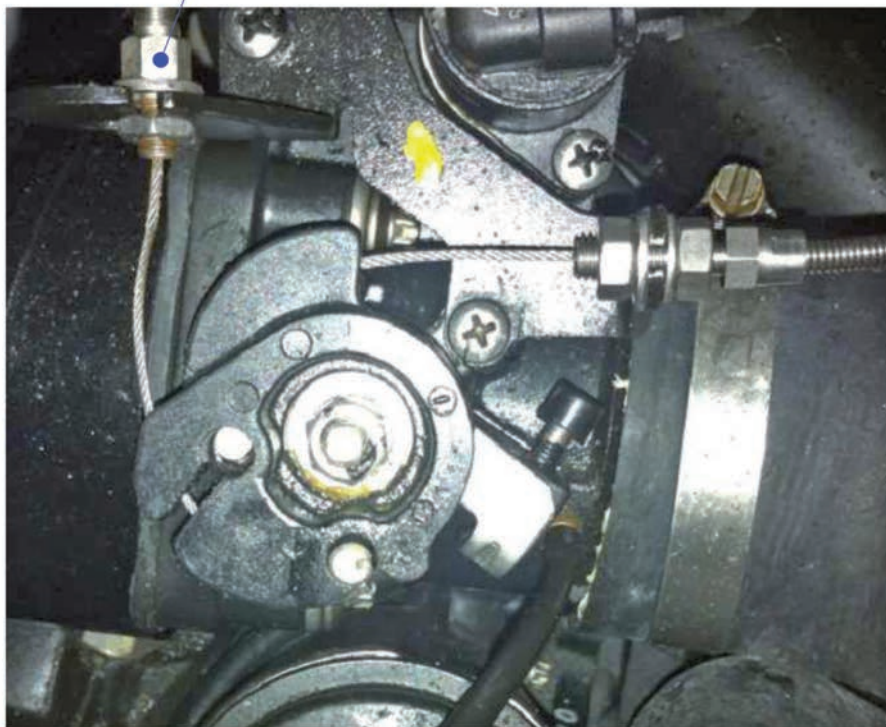
**INSTRUCTIONS: SEADOO**

ALL MODELS EXCEPT THOSE WITH THE ELECTRIC THROTTLE

SET THE THROTTLE OF THE FLYBOARD IN PARALLEL WITH THE THROTTLE OF THE PWC

FB02103

FB02104



FB02105

FB02106

FB02107

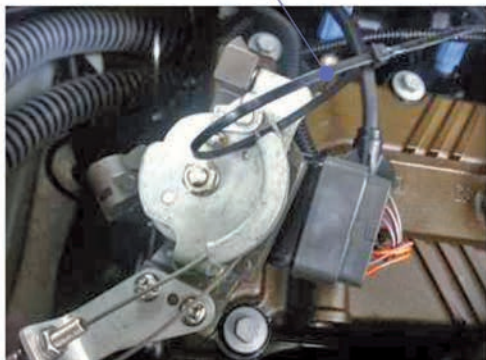
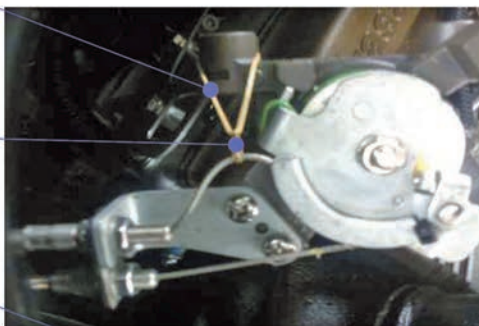
**INSTRUCTIONS: KAWASAKI 300**

1. SET THE THROTTLE OF THE FLYBOARD IN PARALLEL WITH THE THROTTLE OF THE PWC USING THE PART ITEM.FB02104
2. PUT THE ELASTIC ITEM.FB02105 AS IN THE PICTURE
3. INSERT THE CLAMP FB02107 TO ATTACH THE TWO CABLES TOGETHER AS SHOWN IN THE PICTURES



FB02104

FB02103



FB02107

INSTRUCTIONS: KAWASAKI (ALL THE FOURTH STROKE)

1. SET THE THROTTLE OF THE FLYBOARD IN PARALLEL WITH THE THROTTLE OF THE PWC USING THE PART ITEM.FB02104
2. INSERT THE CLAMP FB02107 TO ATTACH THE TWO CABLES TOGETHER AS SHOWN IN THE PICTURES



FB02107

FB02104

FB02103

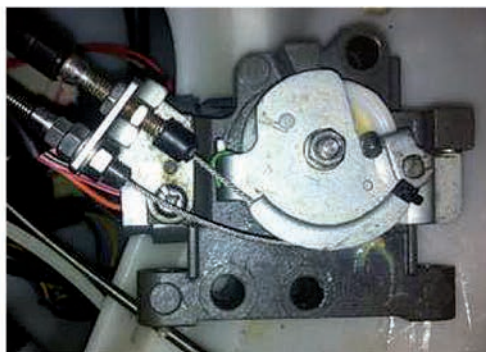
**INSTRUCTIONS: YAMAHA**

1. SET THE THROTTLE OF THE FLYBOARD IN PARALLEL WITH THE THROTTLE OF THE PWC USING THE PART ITEM. FB02104
2. INSERT THE CLAMP FB02107 TO ATTACH THE TWO CABLES TOGETHER AS SHOWN IN THE PICTURES

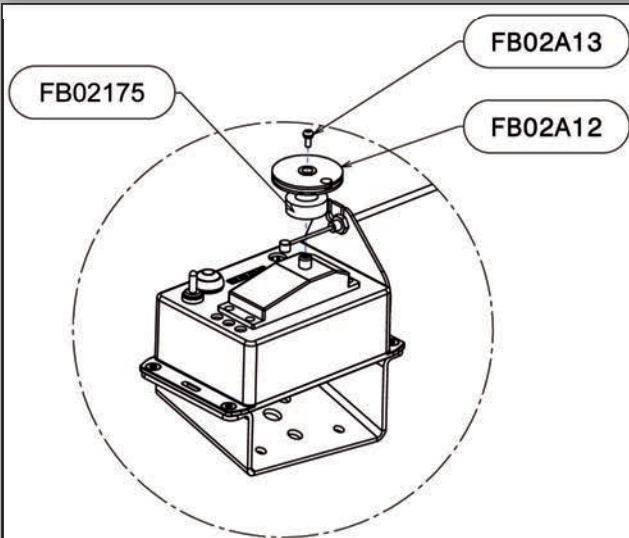

INSTRUCTIONS:

PERFORM TENSION ADJUSTMENT BY ROTATING THE PULLEY ITEM. FB02A12 ON THE DRIVE, MAKE FINE ADJUSTMENTS USING THE NUTS ON BOTH SIDES OF THE THROTTLE CABLE. SPREAD SILICONE GREASE OR VASELINE IN LARGE QUANTITY ON THE PULLEY BEFORE INSERTING IT ON THE ENGINE IN ORDER TO PROTECT IT FROM THE SALT

*****WARNING*****

THE PWC THROTTLE MUSTN'T BE IN APERTURE STOP IF THE SERVOMOTOR IS NOT 100% OPENED. THE SERVOMOTOR WILL EXERT TOO MUCH TENSION ON THE CABLE WHEN IT IS 100% OPENED. THIS WILL DAMAGE ALL MECHANICAL PARTS SUCH AS FB02A12 AND FB02103 OR THE SERVOMOTOR ITSELF. EXERCISING ITS MAXIMUM TORQUE IT CAN BE SERIOUSLY DAMAGED OR DESTROYED.

IT IS THEREFORE RECOMMENDED TO LEAVE A SLIGHT GAP ON THE CABLE TENSION AT THE OPENING TO 100%.

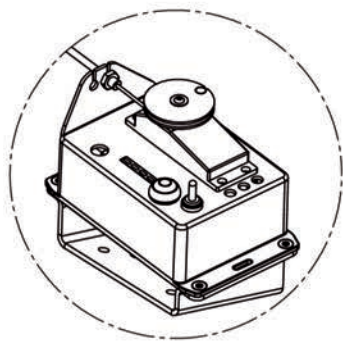
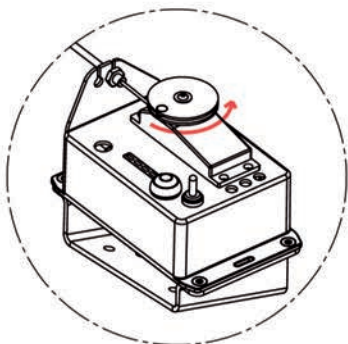

FB02108

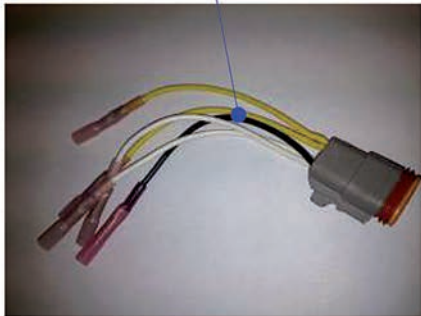

FB02109



CRIMPING

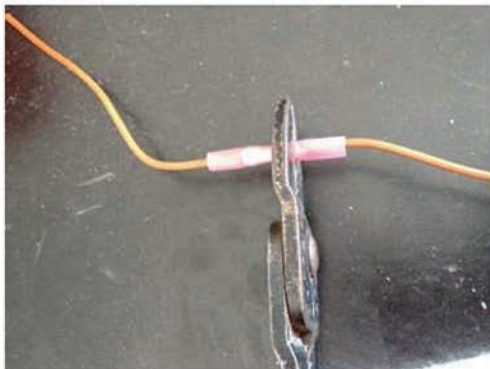

SLAKE THE PODS

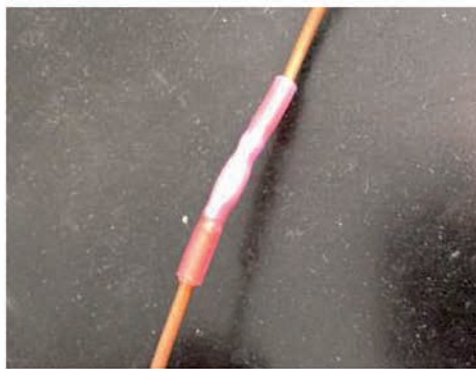
**INSTRUCTIONS:**

SET THE UNIVERSAL HARNESS ON THE PWC REFERRING TO THE APPROPRIATE ASSEMBLY SHEET.

1. CRIMP ALL THE PODS TO ENSURE ELECTRICAL CONTINUITY

2. RETRACT THE PINK PODS WITH A LIGHTER OR A HOT AIR BLOWER TO SLAKE THE CONNECTION

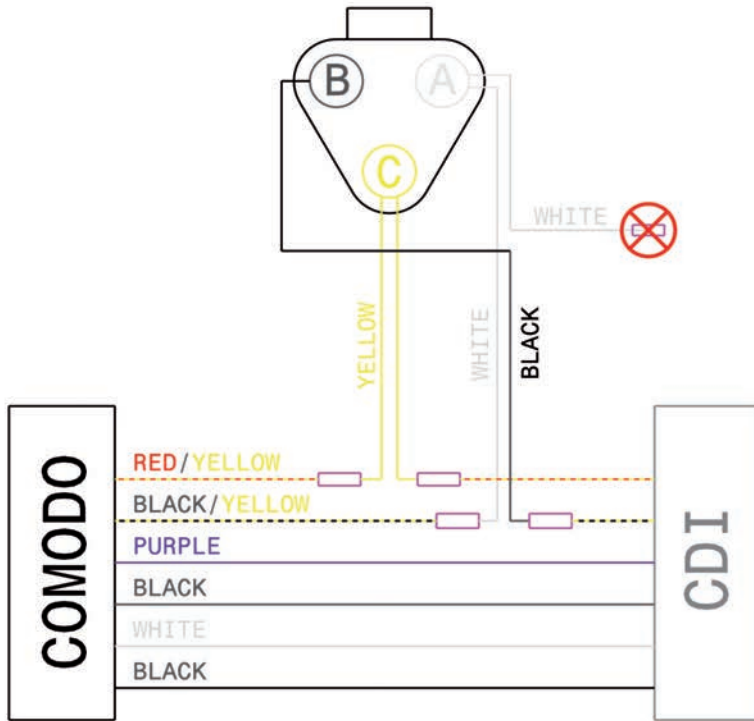

INSTRUCTIONS: SEAD00

1. CUT THE YELLOW AND BLACK WIRE UPSTREAM GREY MALE 6 WAY POD - STRIP THE TWO SIDES OF THE WIRE – CRIMP AND SLAKE
2. CUT THE YELLOW AND RED WIRE UPSTREAM OF THE SAME GREY POD- STRIP THE TWO SIDES OF THE WIRE – CRIMP AND SLAKE THE 2 PINK PODS OF THE YELLOW WIRES OF THE ADAPTER.
3. RETRACT THE PINK POD OF THE WHITE WIRE TO ISOLATE IT

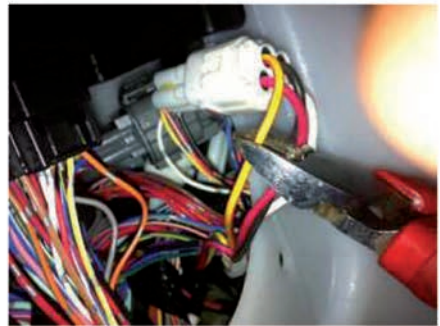
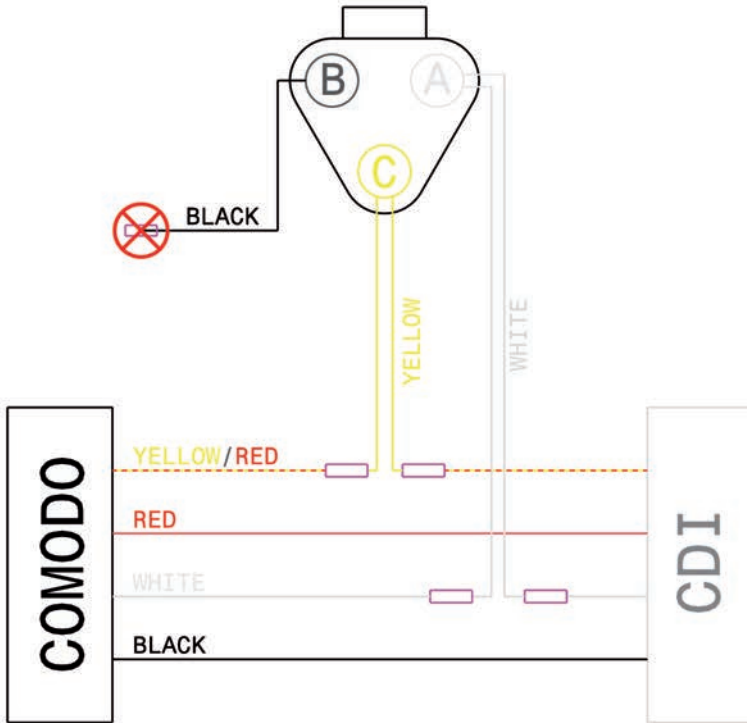

INSTRUCTIONS: KAWASAKI

1. CUT THE WHITE WIRE UPSTREAM OF WHITE MALE POD - STRIP THE TWO SIDES OF THE WIRE - CRIMP AND SLAKE THE 2 PINK PODS OF THE WHITE WIRE OF THE ADAPTER
2. CUT THE YELLOW/RED WIRE UPSTREAM OF THE WHITE MALE POD - EXPOSE THE 2 SIDES OF THE WIRE - CRIMP AND SLAKE THE 2 PINK PODS OF THE YELLOW WIRE OF THE ADAPTER
3. RETRACT THE PINK POD OF THE BLACK WIRE TO ISOLATE IT

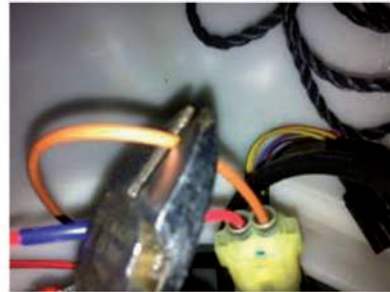
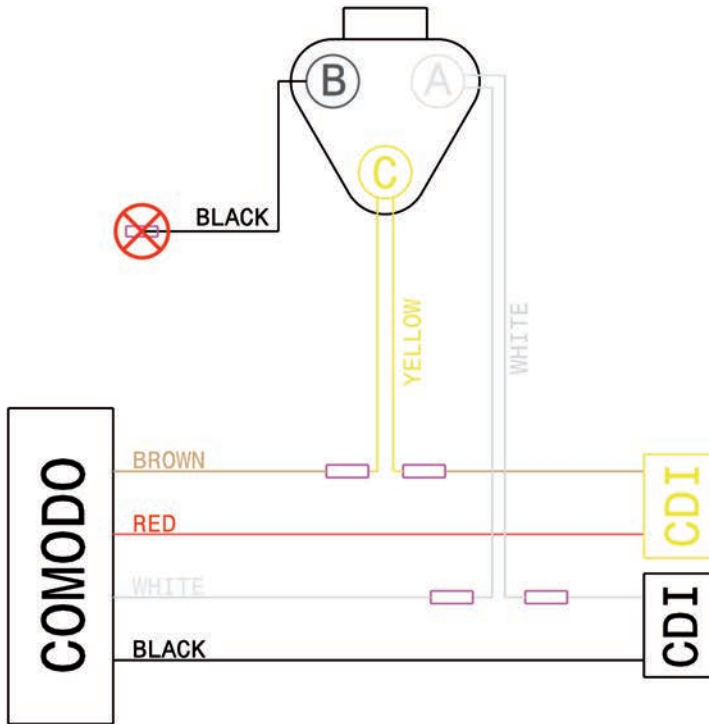

INSTRUCTIONS: YAMAHA

1. CUT THE WHITE WIRE UPSTREAM OF BLACK MALE POD - STRIP THE TWO SIDES OF THE WIRE - CRIMP AND SLAKE THE 2 PINK PODS OF THE WHITE WIRE OF THE ADAPTER
2. CUT THE BROWN WIRE UPSTREAM OF THE YELLOW MALE POD - EXPOSE THE 2 SIDES OF THE WIRE - CRIMP AND SLAKE THE 2 PINK PODS OF THE YELLOW WIRE OF THE ADAPTER
3. RETRACT THE PINK POD OF THE BLACK WIRE TO ISOLATE IT

Ne jamais laisser le raccord femelle débranché dans l'eau sans éteindre le boîtier
Never let the female coupling disconnected in the water without switching off the case.

Ne jamais connecter le raccord avec de l'eau à l'intérieur
Never connect the thread with Water inside.

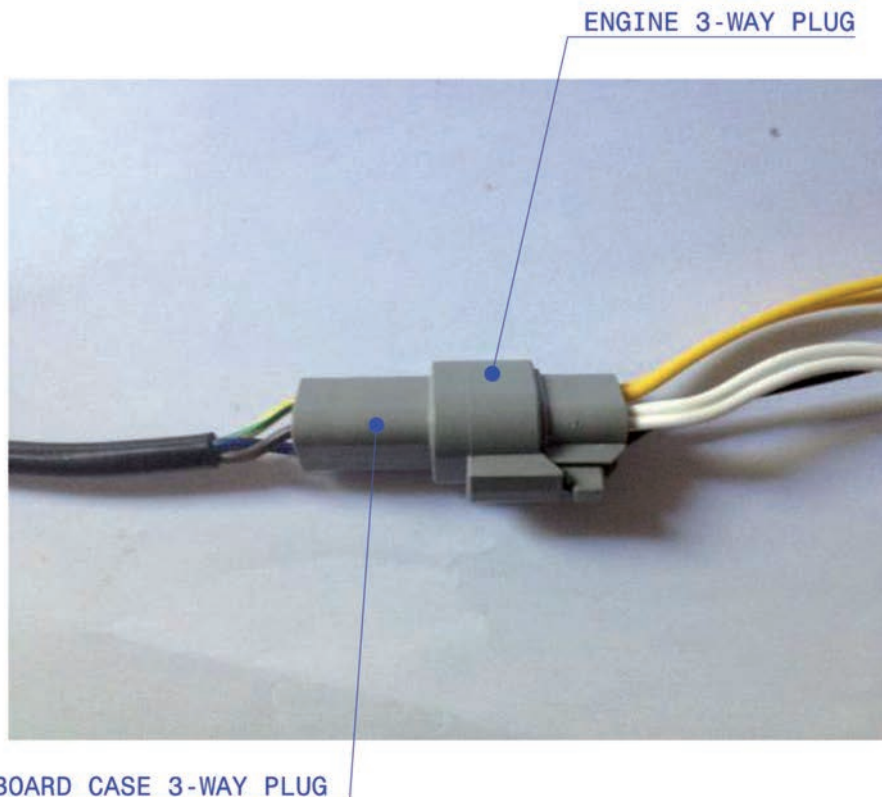
**INSTRUCTIONS:**

CONNECT THE GREY FEMALE 3-WAY LUG OF THE HOUSING TO THE MALE 3-WAY LUG OF THE ADAPTER PREVIOUSLY INSTALLED ON THE PWC

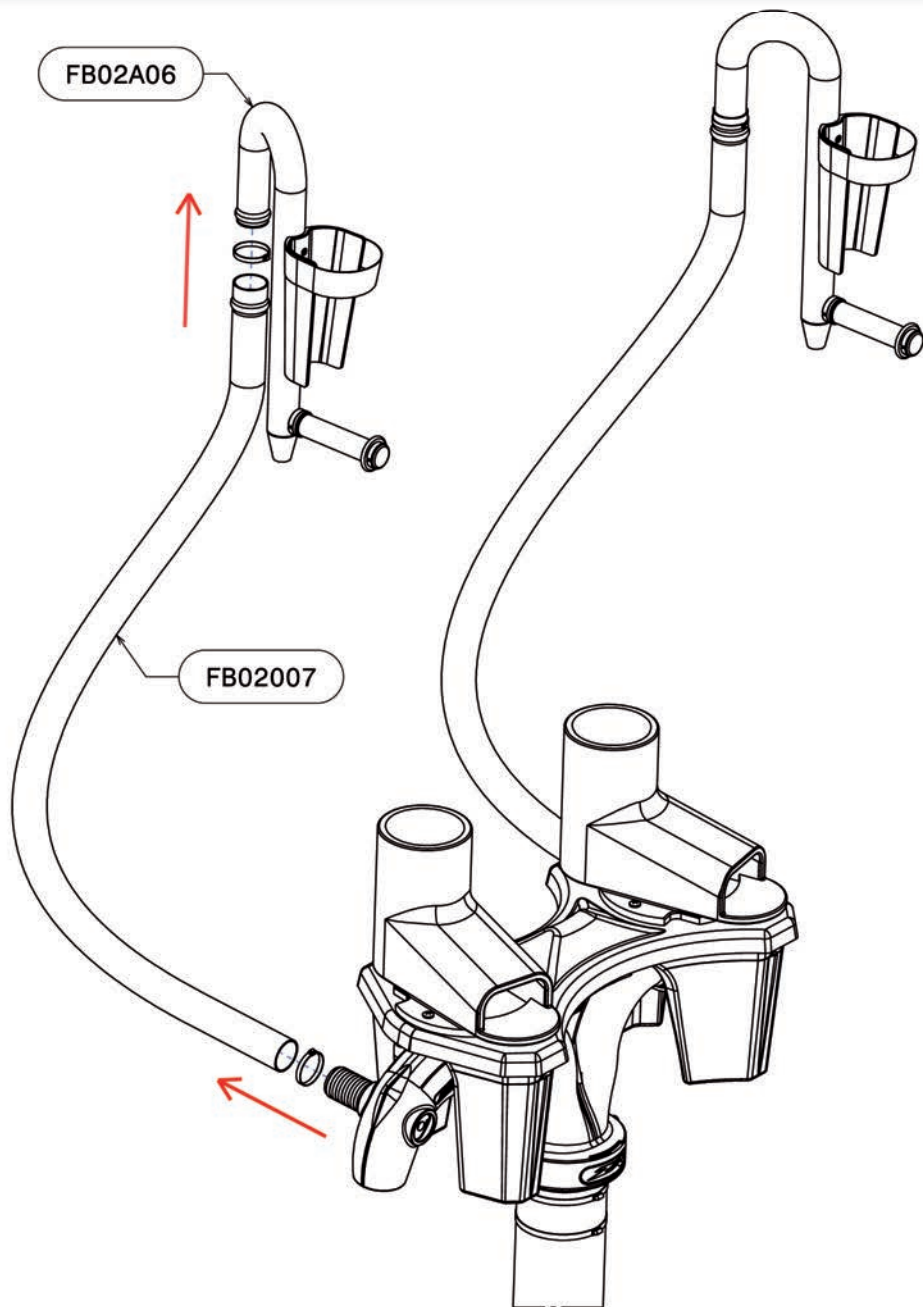

INSTRUCTIONS:

REMOVE THE RIGHT STABILIZER FB02A06 AND THE HOSE FB02007

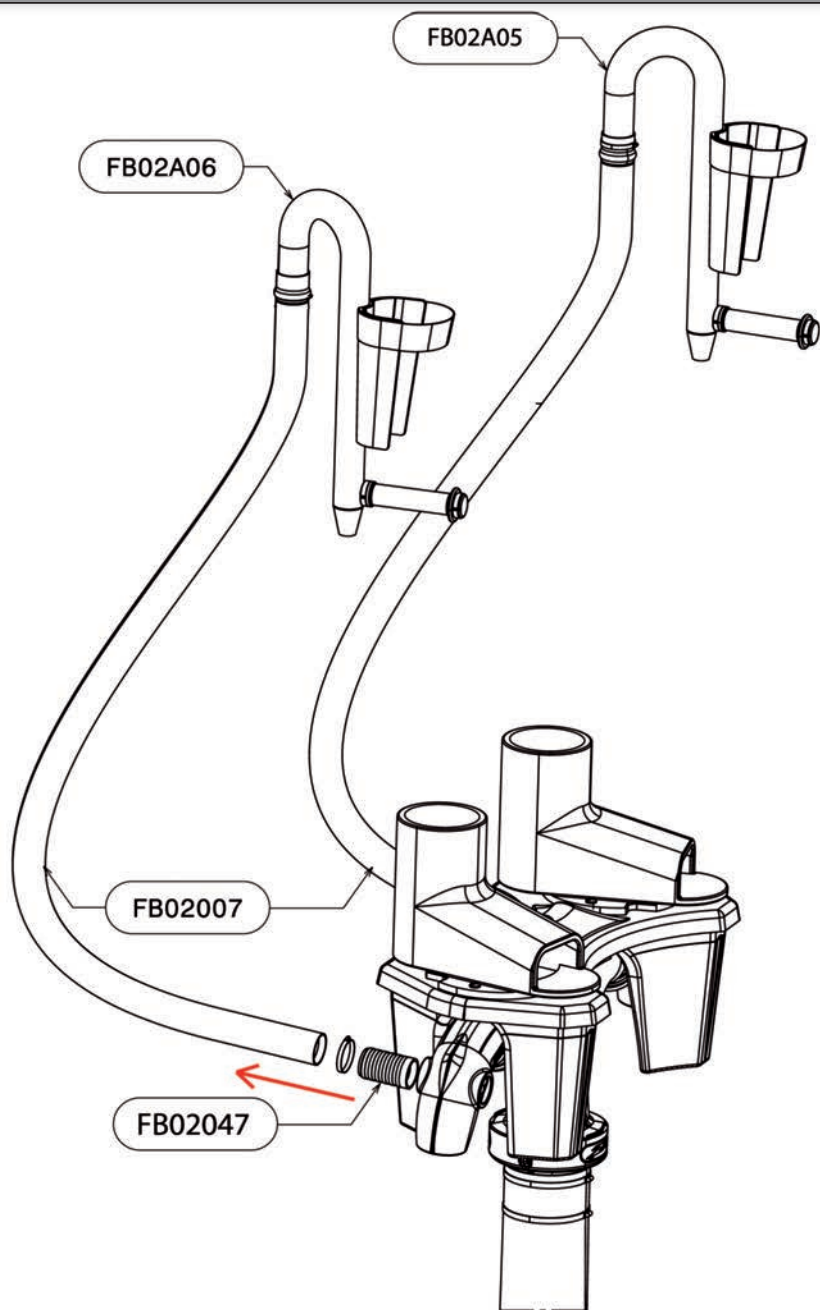
**INSTRUCTIONS :**

- REMOVE THE RIGHT STABILIZER FB02A06, THE LEFT FB02A05, PIPES FB02007 AND TWO FOOTED NOZZLE FB02047

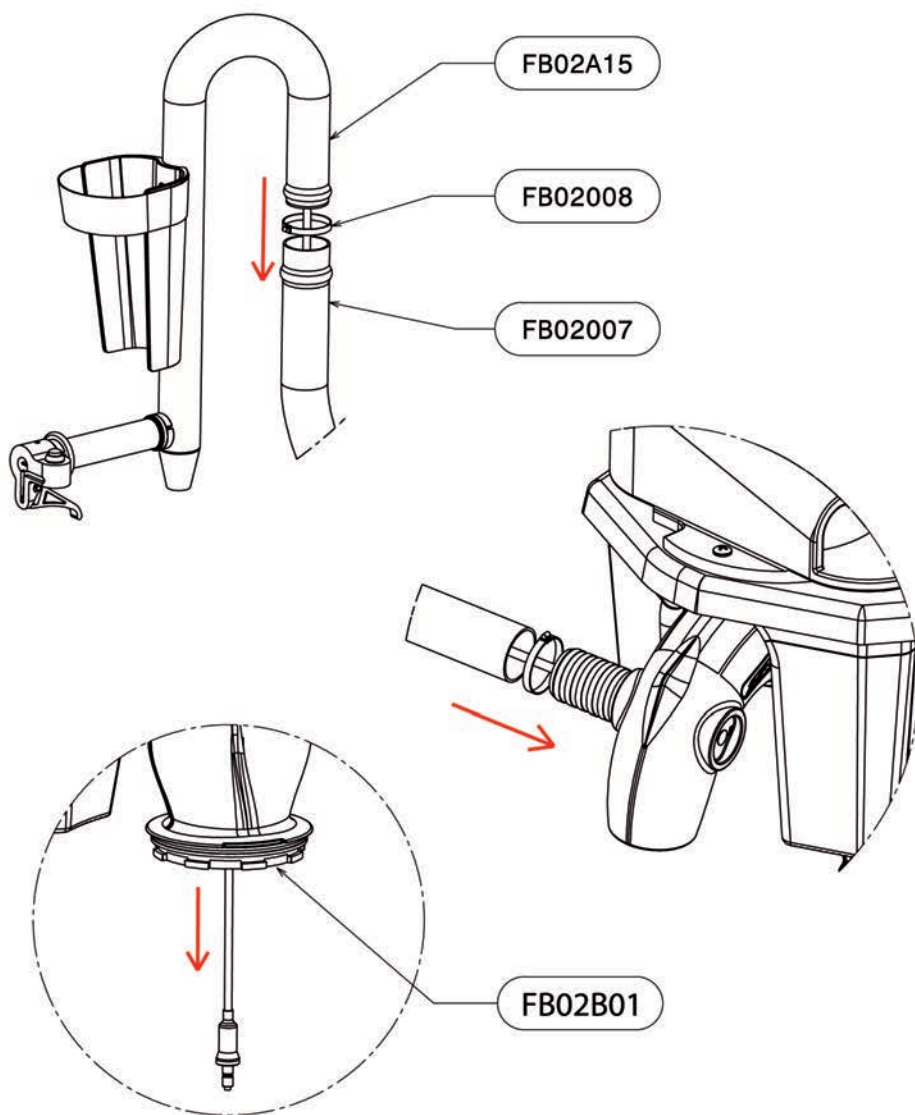

INSTRUCTIONS:

- INSERT THE PLUG AND THE CABLE THROUGH THE HOSE FB02007
- SLIDE IT THROUGH THE BOARD TO GET IT OUT THE Y CONNECTOR FB02B01
- PLACE THE HANDLE FORWARD THE FLYBOARD
- TIGHTEN THE 2 CLAMPS FB02008 (TORQUE 10N/m)

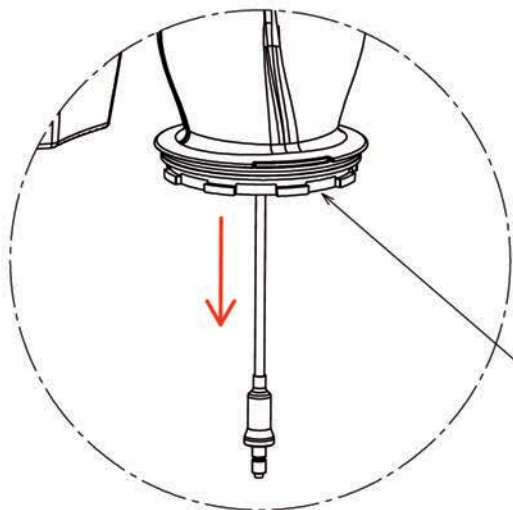
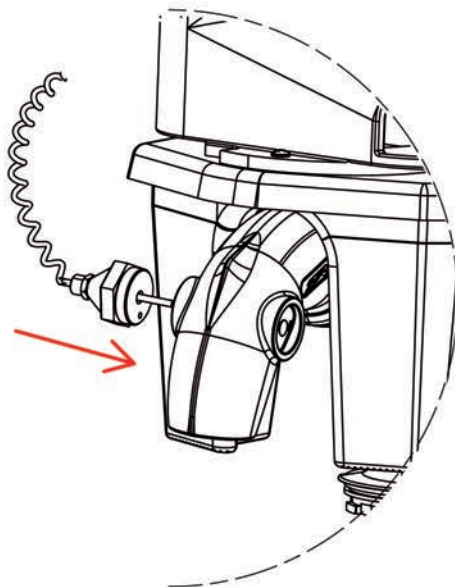
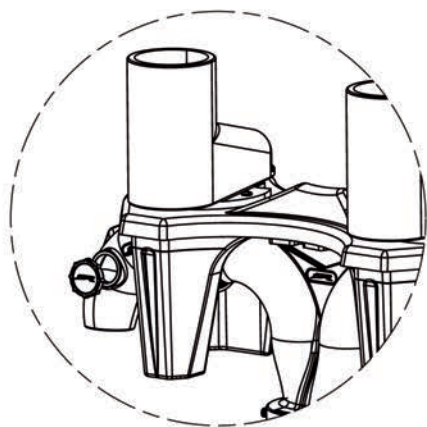

FB02B01

INSTRUCTIONS:

- INSERT THE PLUG AND THE CABLE THROUGH BOARD TO GET IT OUT THE Y CONNECTOR FB02B01

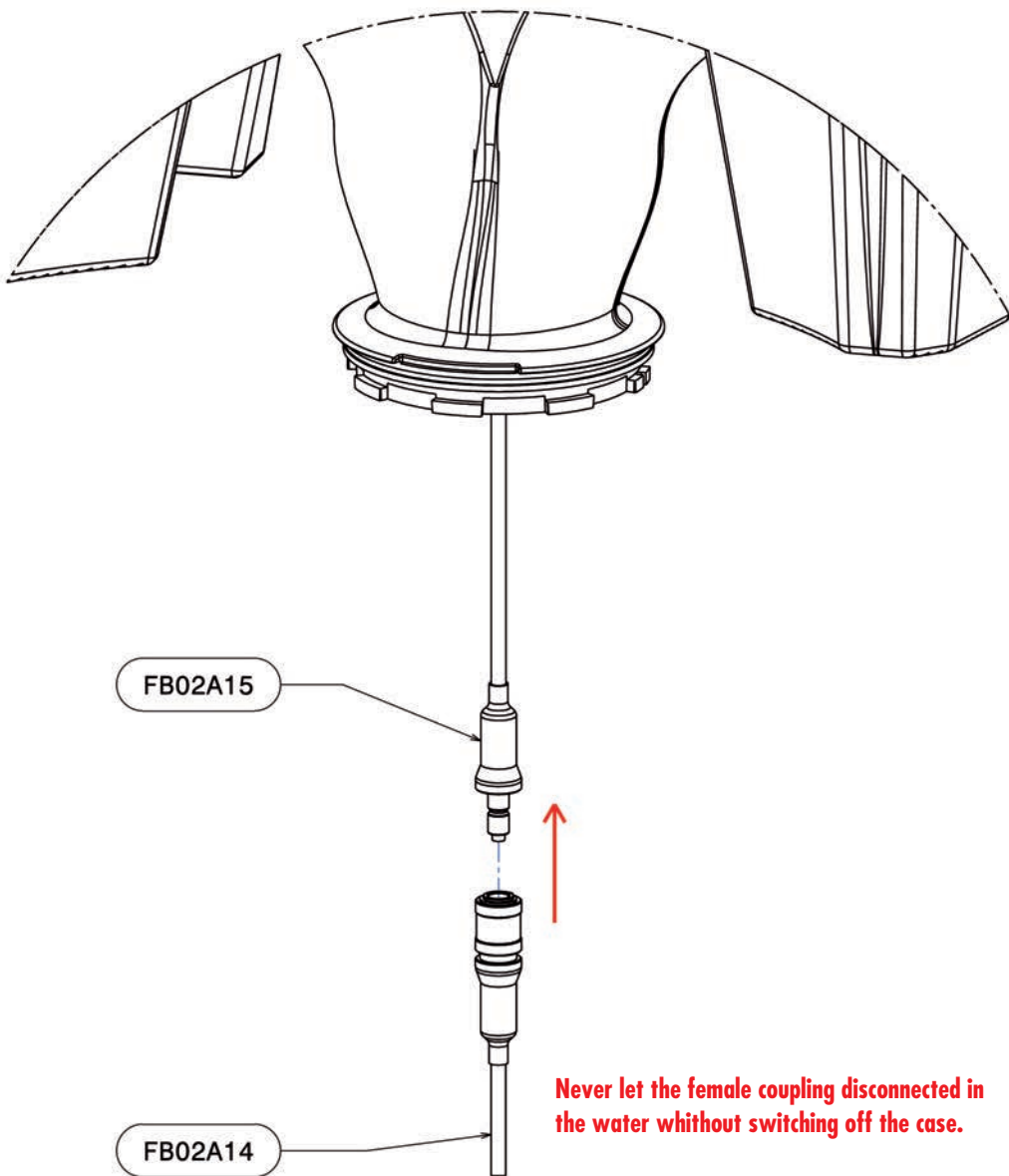

Never let the female coupling disconnected in the water without switching off the case.

Never connect the thread with Water inside.

INSTRUCTIONS:

- CONNECT TOGETHER PLUGS FB02A14 & FB02A15
- RINSE BOTH PARTS OF THE COUPLING WITH FRESHWATER
- USE A NONAGGRESSIVE SILICONE SPRAY FOR THE O-RINGS

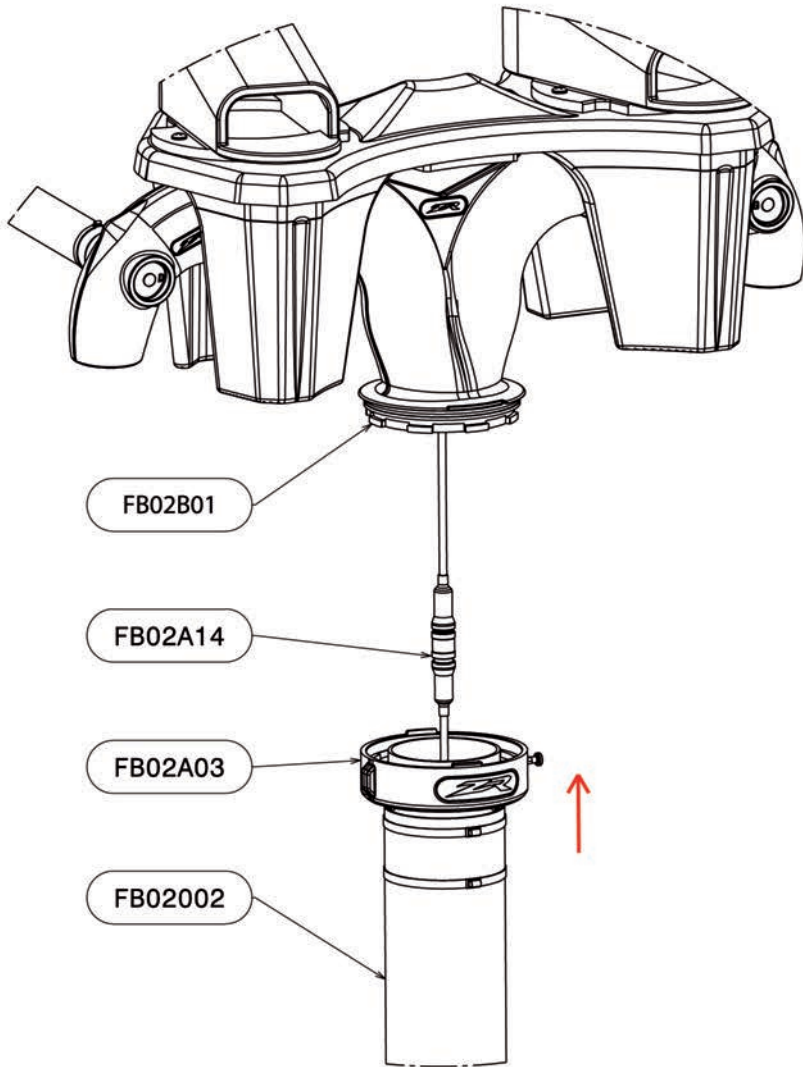
**INSTRUCTIONS:**

- SLIDE THE CABLE FB02A14 THROUGH THE PIVOTALHOSE FB02A03 & THE HISE FB02002
- CONNECT TOGETHER THE PIVOTAL HOSE AND Y CONNECTOR FB02B01

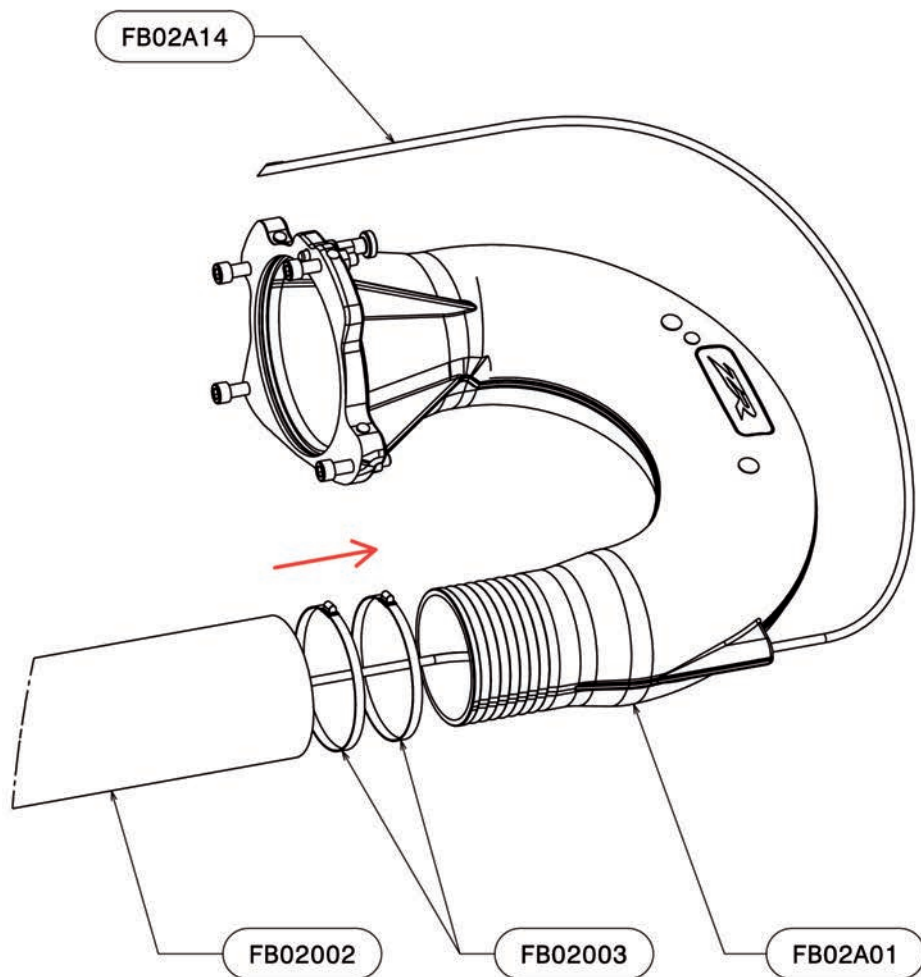

INSTRUCTIONS:

- INSERT THE CABLE FB02A14 INSIDE THE EQUIPPED ELBOW FB02A01
- TIGHTEN THE 2 CLAMPS (TORQUE 10 N/m)

**INSTRUCTIONS:**

1. TENSION THE HOSE OF THE FLYBOARD IN ORDER TO HAVE NO TWIST BETWEEN THE FLYBOARD AND THE ELBOW #FB02A01
2. PULL MODERATELY ON THE CABLE TO TENSE IT INSIDE THE HOSE

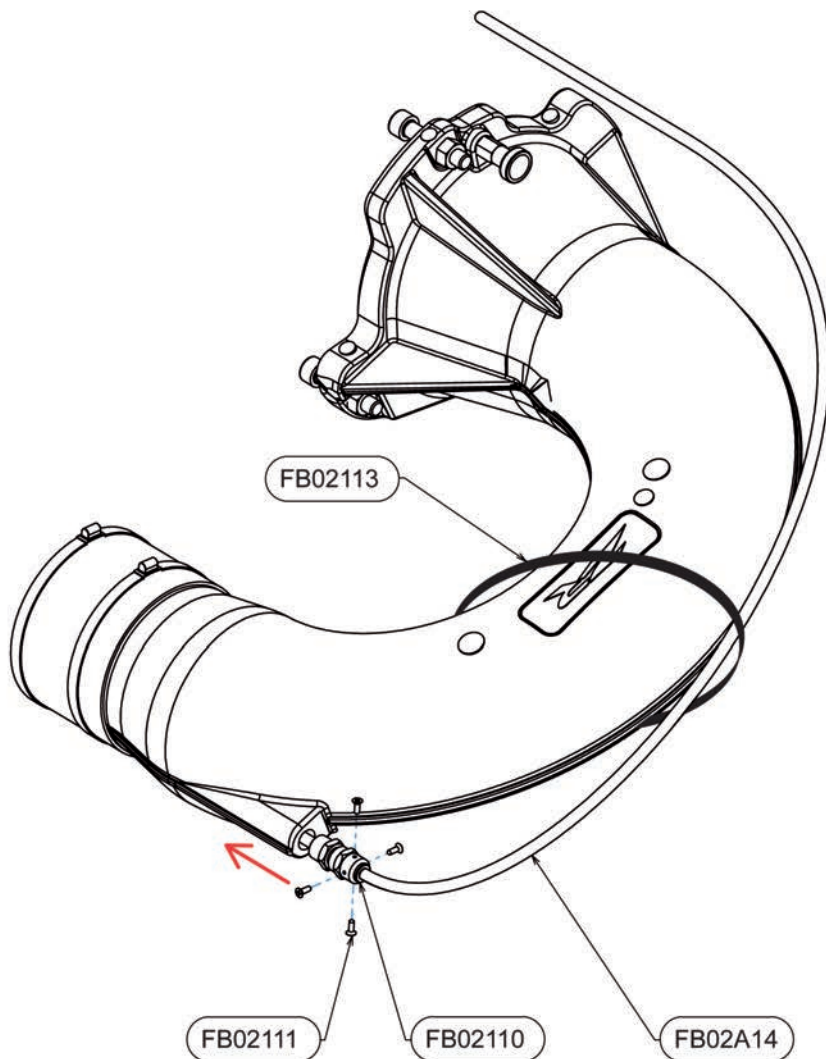

INSTRUCTIONS:

- CONNECT & TIGHTEN TOGETHER THE GLAND FB02110 & THE CABLE FB02A14 IN TENSION
- PUT THE 4 SCREWS FB02111 TO HOLD THE CABLE
- PUT THE BIG CLAMP (RIZLAN TYPE) FB02113 TO TIGHTEN THE CABLE

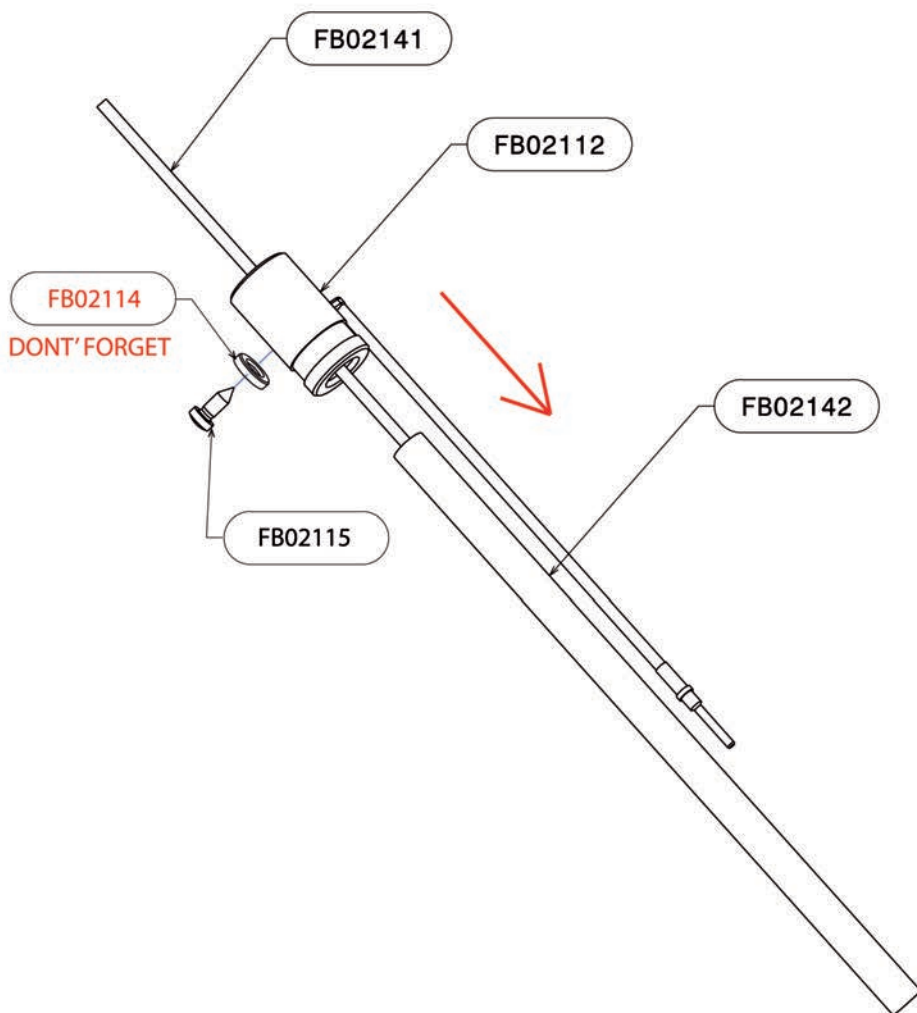
**INSTRUCTIONS:**

- ASSEMBLE THE CABLE TIP FB02112 AND TIGHTEN FULLY THE SCREW FB02115
- CHECK THE GROUND OF FB02112

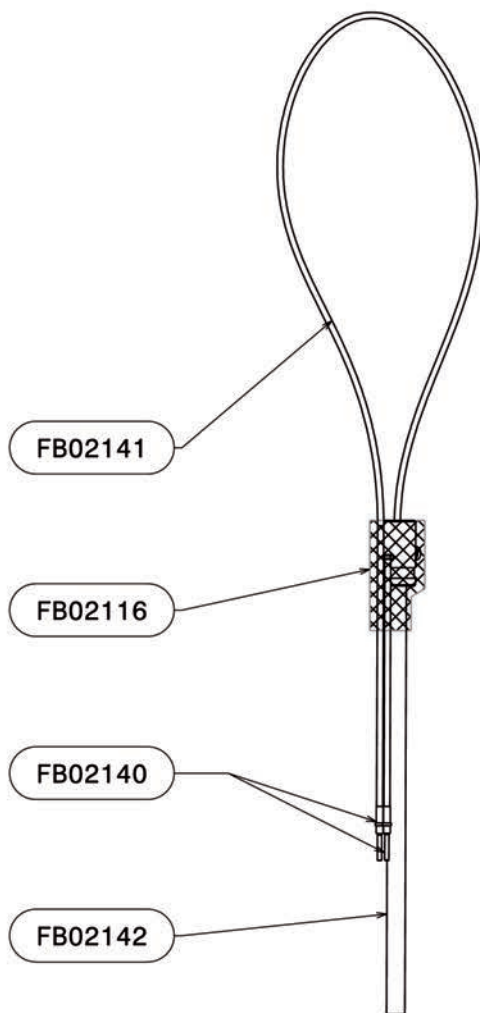
**INSTRUCTIONS:**

- MAKE A LOOP WITH THE CABLE FB 02141 TO HAVE ALIGNED THE 2 PODS FB02140
- FIX THE ASSEMBLY WITH THE HEATSHRINK FB02116

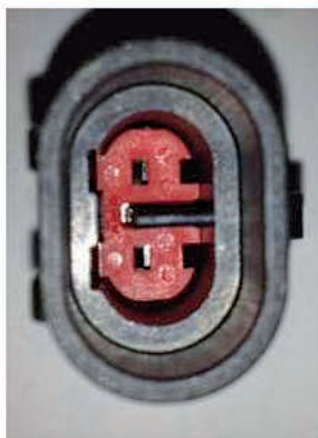
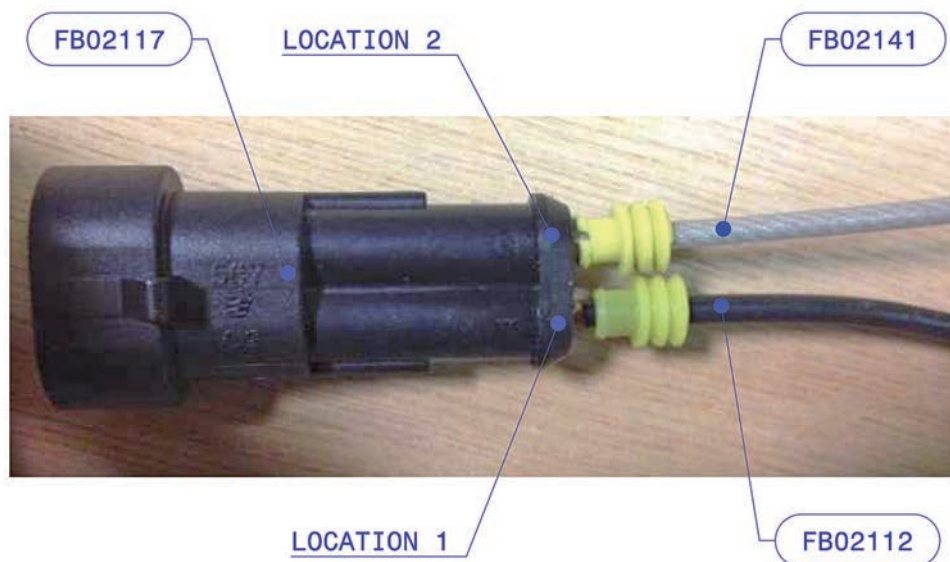
**INSTRUCTIONS:**

- INSERT THE BLACK WIRE FB02112 (FLYBOARD SIGNAL) INSIDE THE LOCATION N°1 OF THE FB02117 POD
- INSERT THE GREY WIRE FB 02141 (GROUND SIGNAL) INSIDE THE LOCATION N° 2 OF THE FB02117 POD
- PUSH THE WIRES UNTIL HEARING A SHORT CLIP
- PRESS THE RED PLASTIC TO LOCK THE WIRE USING A SMALL SCREWDRIVER

CALIBRATION TO DO

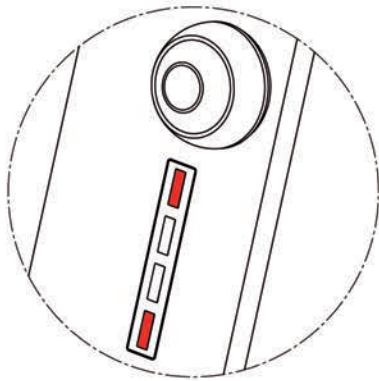

CALIBRATION IN PROGRESS

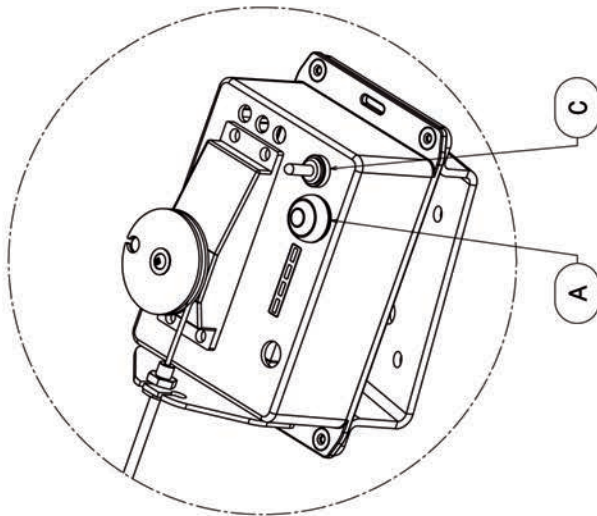
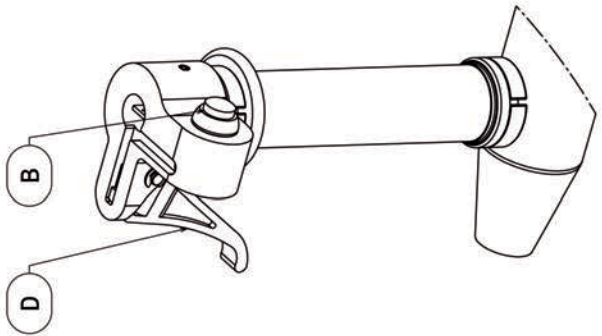
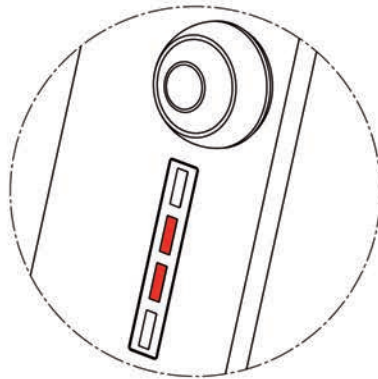

- INSTRUCTIONS:**
 THE HOUSING MUST BE CALIBRATED AT THE 1ST USE AND CAN BE CALIBRATED AGAIN IF THE 1ST AND 4TH LED ARE LIGHTED
1. MAINTAIN THE BUTTONS **A** AND **B** PUSHED
 2. SWITCH ON THE LEVER **C** (LED'S POSITION CHANGE, SEE "CALIBRATION IN PROGRESS")
 3. WHILE MAINTAINING BUTTONS **A** AND **B**, PRESS AND RELEASE 3 TIMES THE TRIGGER THROTTLE **D** TO CALIBRATE THE 0% OPENING POSITION AND 100% OPENING POSITION
 4. RELEASE THE TWO BUTTONS

SEAD00 POSITION

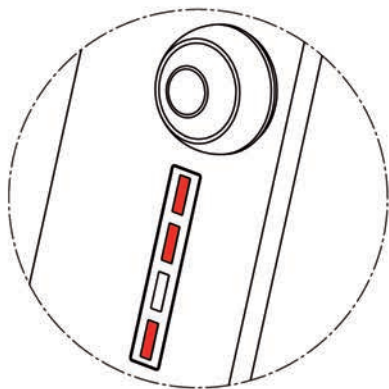

YAMAHA / KAWASAKI POSITION

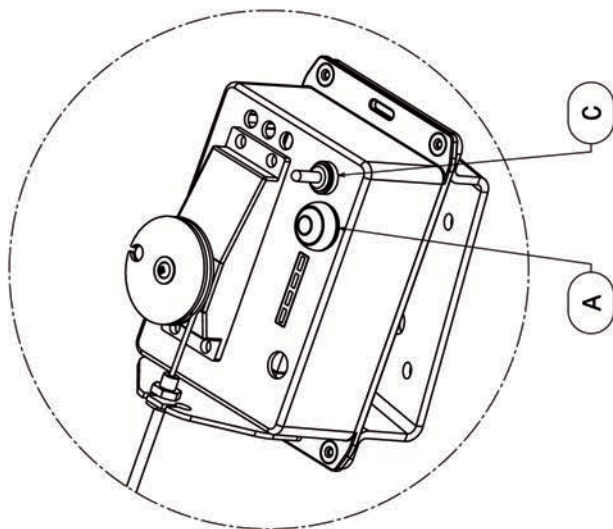
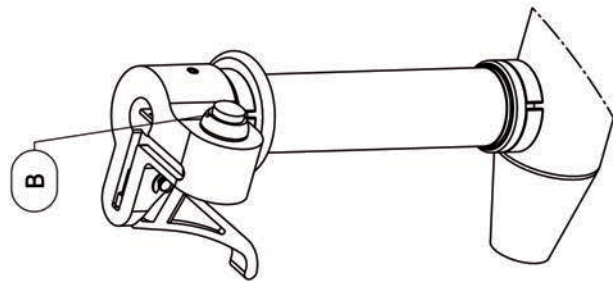
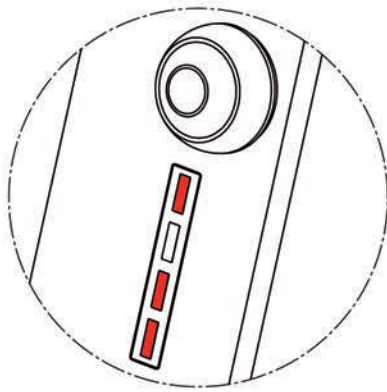
**INSTRUCTIONS:**

1. HOLD THE BUTTON **A**
2. TURN ON THE CASE WITH THE LEVER **C**
3. CHANGE MODE PRESSING SUCCESSIVELY THE BUTTON **B**

PHASE 6 - 3 : CALIBRATION OF THE FLYBOARD' POWER

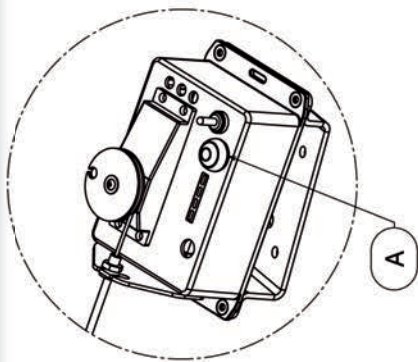

INSTRUCTIONS:
1. CHOOSE THE MODE ACCORDING TO YOUR LEVEL PUSHING THE BUTTON A (CF THE FLYBOARD'S MANUAL)
2. THE CASE KEEPS IN MEMORY THE LAST POSITION OF THE LAST USING

1 LED LIT:
MAXIMUM 4500 RPM

2 LED LIT:
MAXIMUM 5500 RPM

3 LED LIT:
MAXIMUM 7000 RPM

4 LED LIT:
PWC MAXIMUM POWER

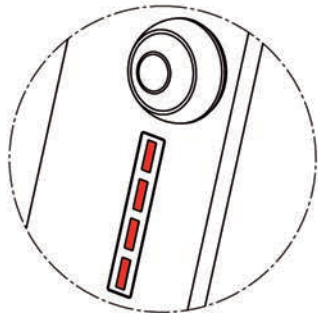
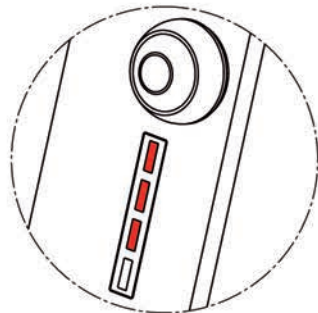
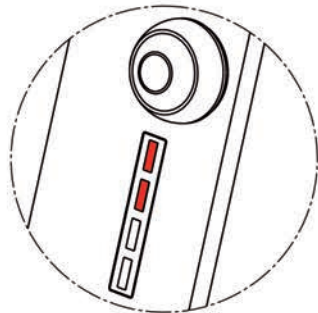
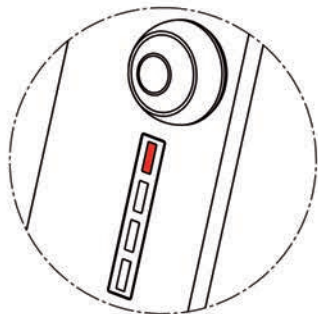

TURN ON THE CASE

THE CIRCUIT BREAKER MUST BE CONNECTED TO USE THE PWC

WARNING !

FOR THE SEADOO THE CIRCUIT BREAKER MUST BE PRESSED FULLY IN THE DESS

IF IT'S NOT DONE CORRECTLY THE SEADOO WON'T RESTART WHEN USING THE FLYBOARD, ESPECIALLY IN "DEAD MAN SAFETY FUNCTION" (EXPLAINED BELOW)

THE CHARACTERISTIC NOISE WILL BE A LONG BEEP INSTEAD OF 2 SHORT AND CLOSE BEEPS BE SURE THAT THE PWC WORKS CORRECTLY BEFORE USING IT

TEST :

- START

- DO NOT USE THE TRIGGER FOR 4 SECONDS, THE ENGINE WILL SHUT OFF

AUTOMATICALLY

- PULL THE TRIGGER, THE SEADOO MUST ISSUE TWO SHORT AND CLOSE BEEPS, THIS

MEANS THAT THE CIRCUIT BREAKER IS PUSHED

TO START, PRESS THE RED BUTTON OF THE FLYBOARD TILL THE PWC STARTS (YAMAHA AND KAWASAKI WILL START HALF A SECOND AFTER PRESSING THE RED BUTTON)

TO STOP THE PWC JUST GIVE A PULSE ON THE SAME RED BUTTON

THE FLYBOARD HAS A "DEAD MAN SAFETY FUNCTION":

IF THE TRIGGER IS NOT USED DURING MORE THAN 4 SECONDS, THE ENGINE OF THE PWC WILL STOP AUTOMATICALLY.

TO START AGAIN JUST PULL THE TRIGGER AND PUSH THE RED BUTTON OR PUSH THE RED BUTTON TWICE

IF THE CABLE IS CUT OR DISCONNECTED WHEN USING, THE POWER WILL BE REDUCED PROGRESSIVELY UNTIL THE ENGINE WILL BE TURNED OFF

BEFORE START AGAIN BE SURE THAT THE CONNECTION CABLES ARE UNDAMAGED

THE CASE MUST BE TURNED OFF TO USE THE PWC WITHOUT THE FLYBOARD (NO LED ON)

MAINTENANCE INSTRUCTIONS

- RINSE WITH CLEAR WATER ALL THE PARTS OF THE ELECTRONIC KIT AFTER USE IN SALTED WATER

- BEFORE EACH STORAGE USE A MILD ANTI-CORROSION SPRAY (SILICONE OIL) FOR THE RUBBER SEALS OF THE CONNECTORS FB02A14 ET FB02A15 AND THE TRIGGER FB02B10.

- DO NOT USE ANTI CORROSION SPRAY ON THE HOOD SEAL OF THE SWITCH, THIS CAN DAMAGE THE RUBBER

- CHECK FREQUENTLY AND BE SURE THAT THERE IS ALWAYS ENOUGH SILICONE GREASE OR VASELINE BETWEEN THE PULLEY FB02A11 AN THE CASE FB02A10 AS IN THE PHASE 2-3

- CHANGE THE FOAM REF FB02175 EVERY 3 MONTHS – IF THIS IS NOT DONE WATER CAN INFILTRATE INSIDE THE ENGINE AND THIS ONE WON'T BE UNDER WARRANTY

- AS WITH ALL OTHER PARTS OF FLYBOARD ® AND AS EXPLAINED IN THE MANUAL OF THE FLYBOARD ®, DO NOT START THE PWC IN AN INSUFFICIENT DEPTH IN THE SAND NOT TO BLOCK FB02A14 AND FB02A15 CONNECTIONS.

KAE0001 : ADAPTATEUR FOE PWC WITH ELECTRONIQUE THROTTLE

FB02250 x1



FB02251 x1

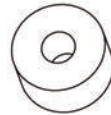

FB02252 x1

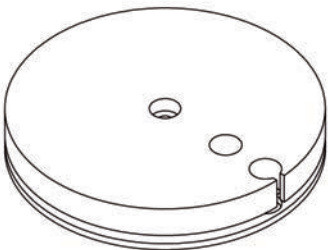

FB02252	01	EXTENSION PULLEY
FB02251	01	SPACER
FB02250	01	EQUIPPED HANDLE ADAPTER
ITEM	NB	DESIGNATION

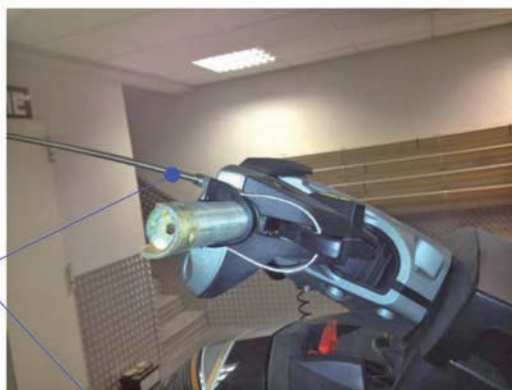

FB02250

**INSTRUCTIONS:**

- REMOVE THE HANDLE SCREW
- INSERT THE ADAPTER FB02250 INSIDE THE HANDLEBAR
- TIGHTEN THE SCREW TO LOCK THE HANDLE ADAPTER FB02250

FB02251

**INSTRUCTIONS:**

- PLACE THE PART FB02251 IN THE HANDLEBAR TO SHIFT THE HANDLE SLIGHTLY OUTWARD
- RETURN THE HANDLE WITH THE ORIGINAL WASHER USING THE BTR M6x35 SCREW



FB02250

INSTRUCTIONS:

- REMOVE THE COVER OF THE STEERING COLUMN
- INSERT THE THROTTLE CABLE INSIDE THE HOLE WHICH COMMUNICATES WITH THE INTERIOR OF THE PWC AS THE OTHER WIRES AND CABLES OF THE PWC
- REPLACE THE COVER OF THE STEERING COLUMN

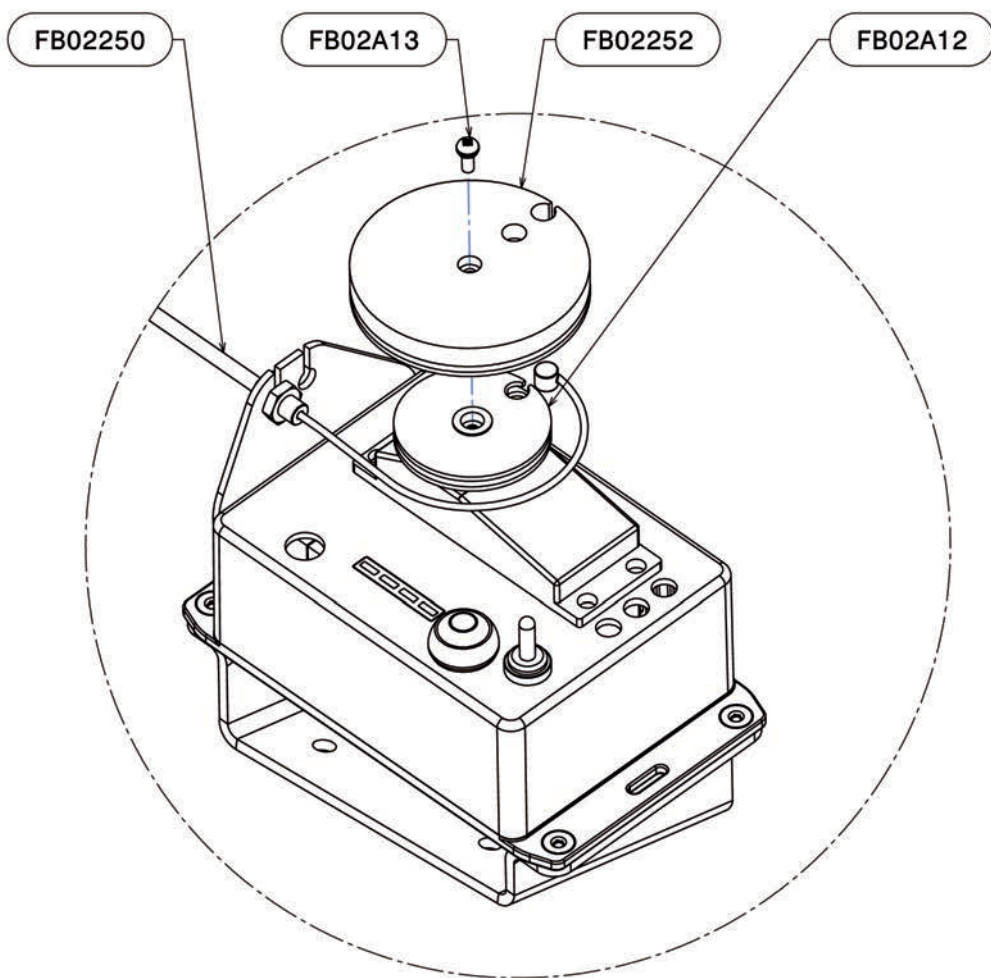
**INSTRUCTIONS:**

- SET THE THROTTLE CABLE FB02250 ON THE ENGINE HOUSING FB02A11
- ASSEMBLE THE PULLEY EXTENSION FB02252 UPON THE PULLEY FB02A12



FLY Board



ZAPATA RACING